



VIBRO/DYNAMICS® RFQ - Machine Tool Specifications

Request for: Quotation Budgetary Estimate

H&O DIE SUPPLY, INC

7200 Interstate 20
KENNE DALE TX 76060
Telephone: 1-800-222-5441 214-630-6660
Fax: 214-630-6693
www.hodie.com
Email: sales@hodie.com

New Customer Quote No. _____

Customer Number: _____ Date: _____

(For Office Use Only)

Salesman: _____

Territory: _____

Name: _____ Phone: _____
Title: _____ Fax: _____
Company: _____ Email: _____
Address: _____ City: _____
State/Province: _____ Postal Code: _____ Country: _____

Send quote via:

- Fax
 Email
 Mail

For the following data, please indicate units of measure: English Metric

I. MACHINE TOOL DATA

Manufacturer: _____
Model Number: _____ Serial Number: _____
Type: (e.g. I.D. grinder, vertical machining center, jig borer, etc...) _____
Control Type: CNC Manual Other: _____
Machine Weight: _____ Maximum Part Weight: _____
Maximum Tooling Weight: _____ Weight of Fixtures (if any): _____
Number of Mounting Points: _____ (See section VI on the next page for more on mounting points)

II. OPERATING SPEED RANGES

Main tool spindle or chuck: _____ RPM's Horizontal or Vertical
Motor spindle: _____ RPM's Horizontal or Vertical
Other rotating member: _____ RPM's Horizontal or Vertical
Describe other rotating member: _____
Is there a balancer? Yes No What type? _____

III. TABLE TRAVERSE (if applicable)

Moving Weight: _____ Which Axis? X Y Z
Maximum Acceleration: _____ Fill in those that apply
Maximum Velocity: _____

IV. OTHER TRAVERSE ACTIONS (if applicable)

Moving Weight: _____ Describe Action: _____
Maximum Acceleration: _____ Which Axis? X Y Z
Maximum Velocity: _____ Fill in those that apply

V. PLEASE PROVIDE A GENERAL ASSEMBLY DRAWING, IF POSSIBLE.



Machine Specifications – page 2

Machine Model
(From front page)

VI. CHECK TYPE OF MOUNTING POINT AND LIST APPLICABLE DIMENSIONS

For the following data, please indicate units of measure: English Metric

If blind tapped hole: Mounting Hole Diameter Pitch Depth

Type A

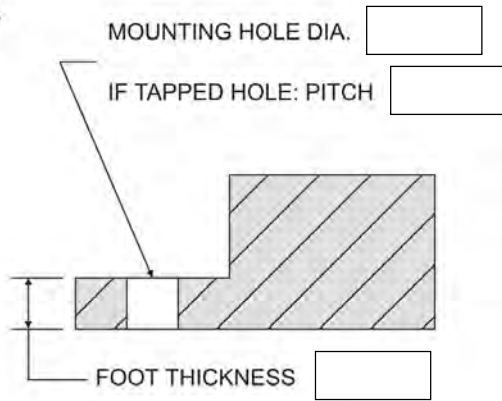

Type B

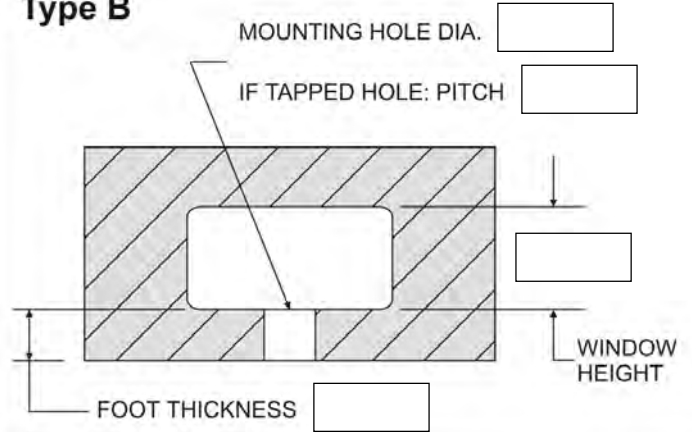

Type C

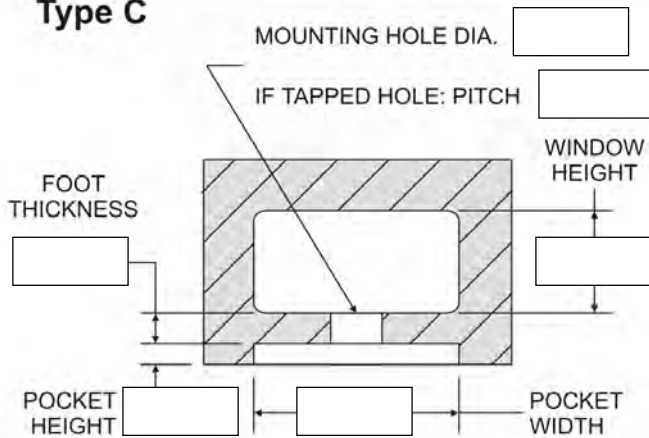

Type D

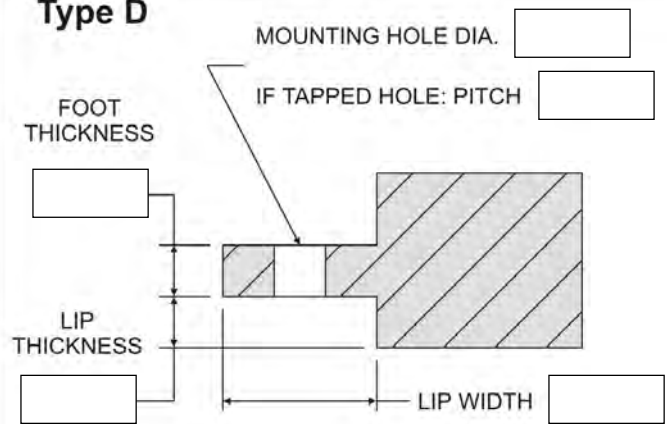

VII. Use the space below for sketches and/or comments on any special considerations.